



AlfaDisc

All-welded Plate Heat Exchanger

Applications

AlfaDisc is suitable for most of the applications, such as general cooling and heating duties, condensation, evaporation, reboiling and stream heating.

Standard design

AlfaDisc is built on the Plate & Shell concept. It is able to withstand higher design pressure, is more compact, is better developed for fatigue applications, has the possibility for asymmetric flow and is cleanable on one side. These features in combination with an attractive price give us a range of competitive advantages over other welded concepts.

The AlfaDisc all-welded plate heat exchanger provides the thermal efficiency and compactness of a plate and frame unit under conditions that would normally call for a shell and tube unit.

Designed for use with liquids, gases and two-phase mixtures at pressure up to 100 bars (PED & ASME) and at temperatures up to 538°C, the Plate&Shell unit works well with aggressive media, such as organic solvents, steam heaters and interchangers that are beyond the capability of a gasketed unit. The unit is also available with removable core design.

Typical capacities

Liquid flow rate

Up to 157 kg/s (2355 gpm) depending on media, permitted pressure drop and temperature program.

Sizes

AlfaDisc 25	AlfaDisc 100
AlfaDisc 50	AlfaDisc 150
AlfaDisc 80	AlfaDisc 200

Working principle

The unit features a plate side and a shell side, which offer high pressure ratings. It has alternating channels for hot and cold media, and can offer true counter-current or co-current flow. Number of passes could be up to 3 passes maximum on each side.



AlfaDisc 50

Nozzle sizes up to DN 700 can be accommodated on the shell side of the exchanger, offering higher steam and liquid flow rates. Nozzles on the plate side can be up to DN 200.

The AlfaDisc unit can be fabricated from dissimilar metals when only one side will be exposed to corrosive conditions.

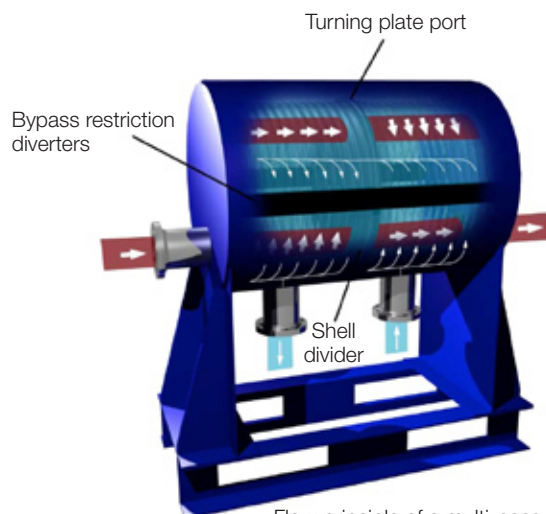

Flow principle of a multi-pass AlfaDisc.

TECHNICAL DATA

Design pressure

CE/PED Vacuum to 100 bars

ASME Vacuum to 100 bars

Design temperature

Carbon steel Shell -45 - 538°C

Stainless steel Shell -160 - 538°C

Maximum heat transfer surface

AlfaDisc 25 4.5 m² (48.5 ft²)

AlfaDisc 50 35 m² (377 ft²)

AlfaDisc 80 62 m² (667 ft²)

AlfaDisc 100 125 m² (1345.5 ft²)

AlfaDisc 150 220 m² (2368 ft²)

AlfaDisc 200 380 m² (4090 ft²)

STANDARD MATERIALS

Shell Material

Mild steel, Epoxy painted or stainless steel

Cover Material

Mild steel, Epoxy painted or stainless steel

Nozzles

Stainless steel, Titanium and 254 SMO

Could be combined with carbon steel flanges

Plate material

316L, Titanium and 254 SMO

STANDARD CONNECTIONS

Model range	Sizes mm (inch)	
	Plateside	Shellside
AlfaDisc25	25 (1)	20 - 100 (1 - 4)
AlfaDisc50	50 (2)	20 - 150 (1 - 6)
AlfaDisc80	80 (3)	25 - 250 (1 - 10)
AlfaDisc100	100 (4)	25 - 350 (1 - 14)
AlfaDisc150	150 (6)	25 - 500 (1 - 20)
AlfaDisc200	200 (8)	25 - 700 (1 - 28)

Pressure ratings

CE/PED PN16, 25&40, PN63 and PN100

ASME ASME cl. 150, 300 & 600 and Class 900

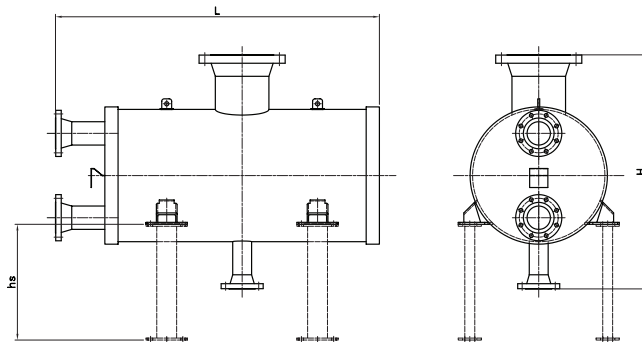

Dimensions (mm)

Model	H ² min/max		L min/max		hs ¹ min/max	
AD25	370	850	275	1945	260	740
AD50	630	1050	290	2010	450	790
AD80	790	1270	310	2070	540	1040
AD100	930	1450	340	2125	640	1220
AD150	1130	1700	380	2205	760	1530
AD200	1450	2400	430	2325	1000	1980

Dimensions (in)

Model	H ² min/max		L min/max		hs ¹ min/max	
AD25	15	33	11	77	10	29
AD50	25	41	11	79	18	31
AD80	31	50	12	81	21	41
AD100	37	57	13	84	25	48
AD150	44	67	15	87	30	60
AD200	57	94	17	92	39	78

¹ Dimensions vary with support type

² Dimensions vary with connection sizes and supports

Particulars required for quotation

- Flow rates or heat load
- Temperature program
- Physical properties of liquids in question (if not water)
- Desired working pressure
- Maximum permitted pressure drop
- Available steam pressure

How to contact Alfa Laval

Up-to-date Alfa Laval contact details for all countries are always available on our website at www.alfalaval.com.